

# INSTALLATION INSTRUCTIONS

## CAR-MON HOSE DROPS

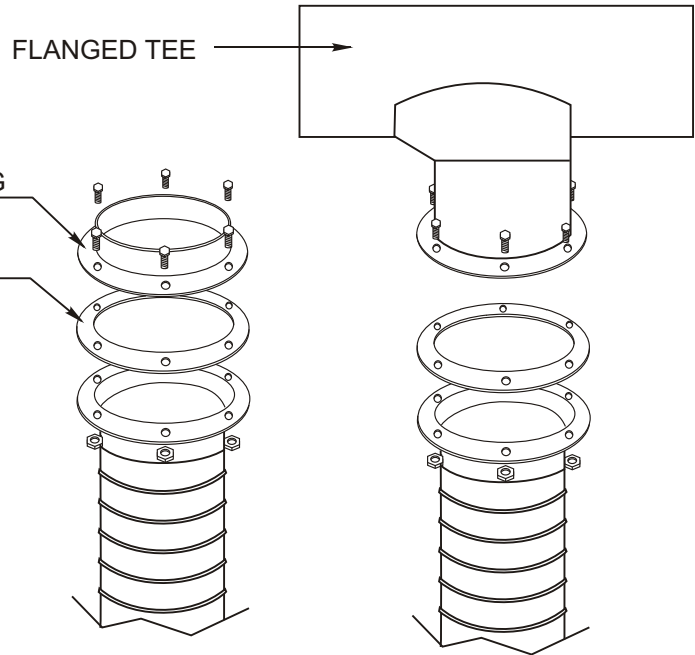
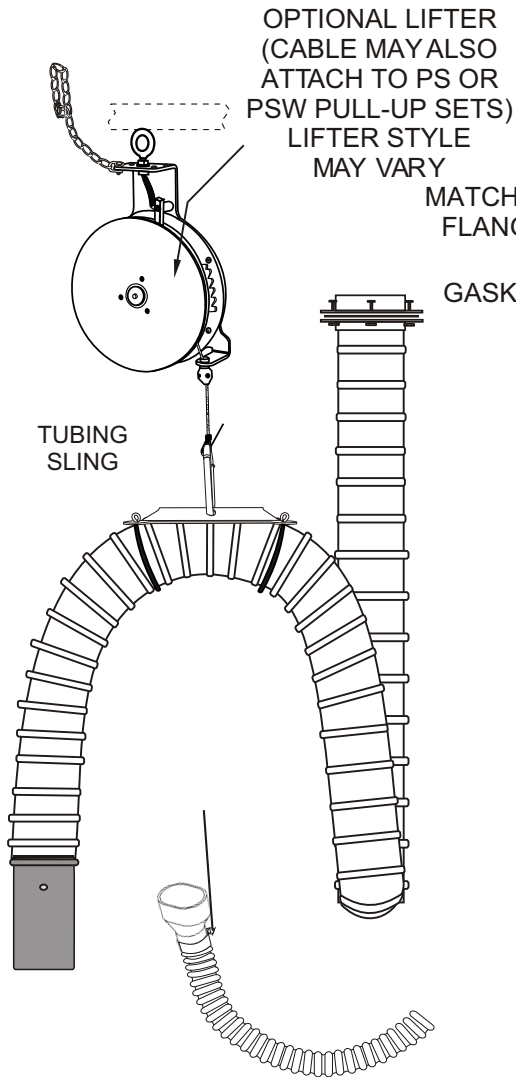

### INSTALLING FLANGED HOSE ASSEMBLIES

1. When flanged tees are not supplied, securely attach matching flange to tap. Using supplied gasket in between flanges, attach flanges together with hardware supplied.
2. When tees are supplied with flanged tap, mount the tubing to the tee using the gasket in between the two flanges, and attach with hardware supplied.
3. When a Car-Mon platform is supplied, the flange on the end of the tube will mount to the bottom of the frame. (With gasket in between)

NOTE: In some instances, a tubing sling is not used. The lifter cable may be attached directly on the adapter or to a cable and clamp directly behind the adapter.

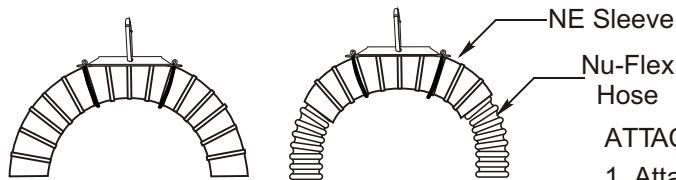

When using a sling with HTX, CLX, or NE hose, the sling is placed directly around the hose. (Left side) When using Nu-Flex hose, it will have a factory installed sleeve of NE hose around the tube which can be moved up or down to position the sling. This is to prevent kinking of the Nu-Flex hose when lifted. (Right side)

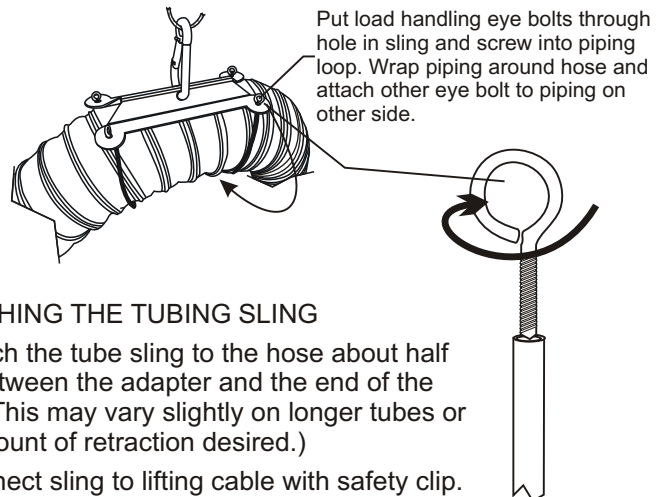

### ATTACHING THE TUBING SLING

1. Attach the tube sling to the hose about half way between the adapter and the end of the tube. (This may vary slightly on longer tubes or the amount of retraction desired.)
2. Connect sling to lifting cable with safety clip. Refer to the Instruction and Operation sheets for the lifter, balancer, or pull-up set.