

CAR-MON SERIES RCO REFUSE CLEAN-OUT PLENUM

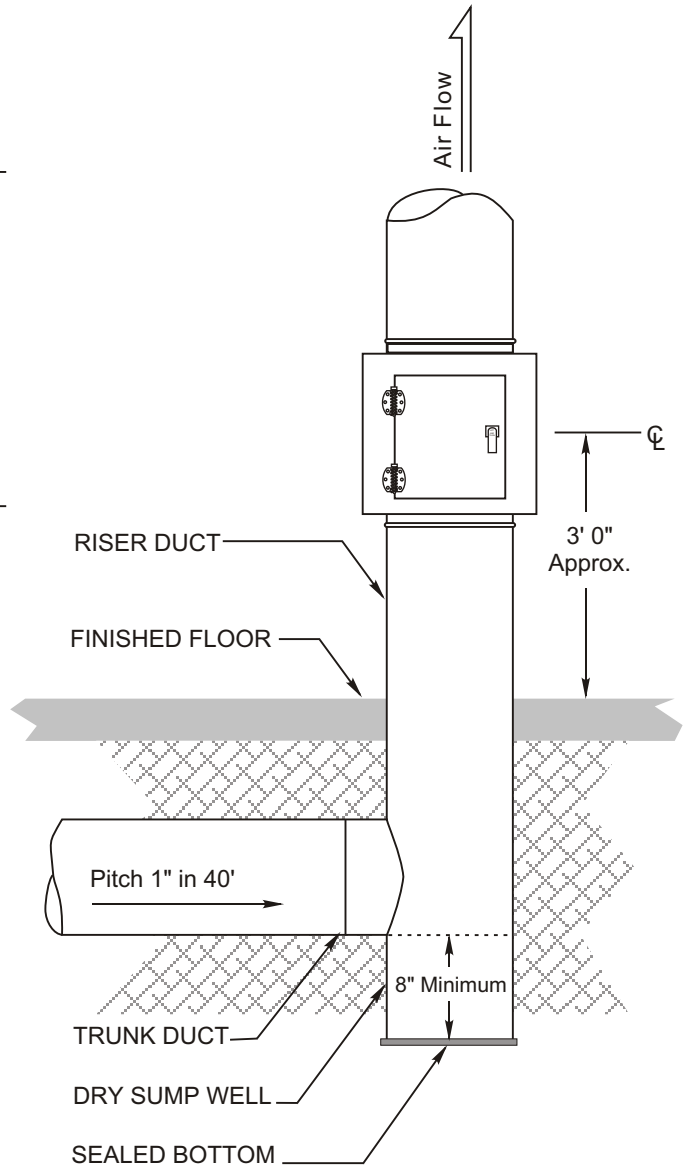
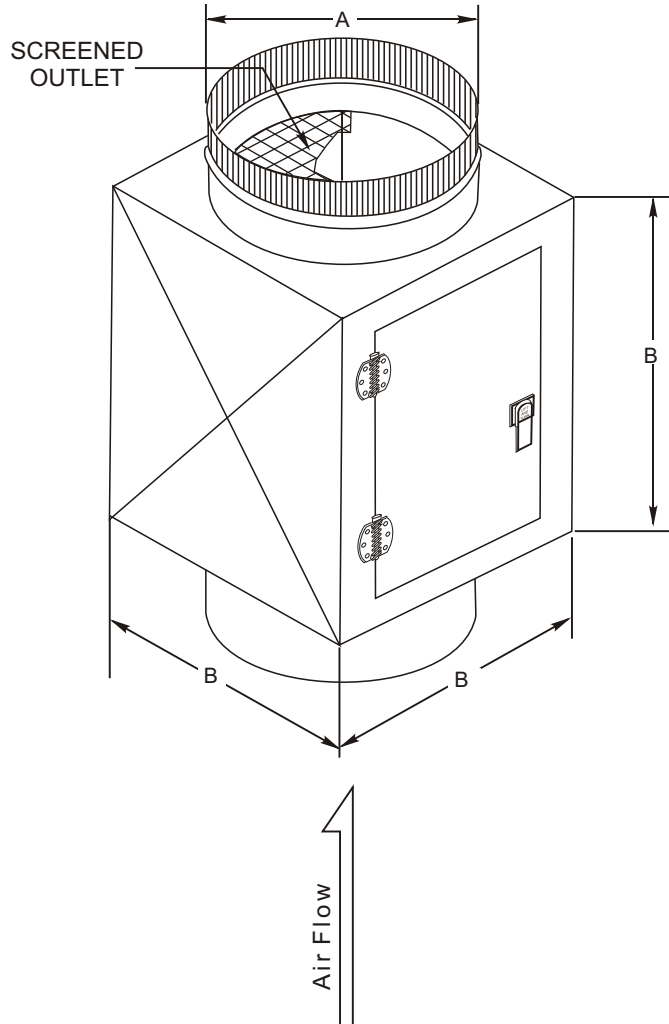

| QTY. | MODEL | A | B |
|------|--------|-----|-----|
| | RCO-10 | 10" | 12" |
| | RCO-12 | 12" | 14" |
| | RCO-14 | 14" | 16" |
| | RCO-16 | 16" | 18" |
| | RCO-18 | 18" | 20" |

Series RCO refuse clean-out plenums are designed as a debris trap to protect the exhaust fan while providing access to the underground ducting system through the riser duct for removal of accumulated refuse and insertion of a sump pump to eject water should the system become flooded.

The refuse clean-out shall be constructed of minimum 20 gauge galvanized steel with positive close, gasketed access door with heavy duty, cad plated, spring loaded leaf spring, and adjustable draw latch. A screen mesh of 1/2" x 1/2" shall be provided across the outlet opening.

Note: Factory reserves the right to change dimensional data without notice.