

CMW/DXi FLANGE MOUNTED DIRECT DRIVE FANS

INTRODUCTION

This manual has been prepared to guide the users of Car-Mon flange mounted fans in the proper installation, operation, and maintenance procedures to insure maximum life with trouble free operation.

RECEIVING

All fans leaving the plant have been carefully inspected and test run to insure they are in the optimum performance operating condition. The carrier assumes full responsibility for material from the time it leaves our plant until it is delivered to the user. Therefore material received should be inspected for damage immediately so that any damage claims against the carrier can be made before acceptance of the shipment. Call carrier if concealed damage is found. Car-Mon will not be responsible for damage not reported to carrier. No equipment is to be returned without an authorized returned goods tag.

STORAGE

If the fan is to be stored for any length of time, appropriate care should be taken to protect bearings, shaft and finished surfaces from moisture, dirt, dust, etc. Do not store other products on top of fan equipment. Periodic inspections of the unit should be made until it is ready to be put into service. Keep in mind that the warranty on the motors starts when material is shipped, not installed. Customer will be responsible for any repairs, even if product is new, if it is stored past the warranty period before it is put into use.

INSTALLATION

For fans shipped that are not mounted to equipment, the installation is quite simple. Line up the flange of the fan to matching flange or mounting holes on platform. Make sure to use the supplied gasket between the fan and platform, and to assure fan outlet is in the proper orientation before attaching the bolts. See diagram below for bolt attachment.

NOTE: DXi FANS WILL HAVE A SLIGHTLY DIFFERENT CONFIGURATION. INSTALLATION INFORMATION WILL BE THE SAME.

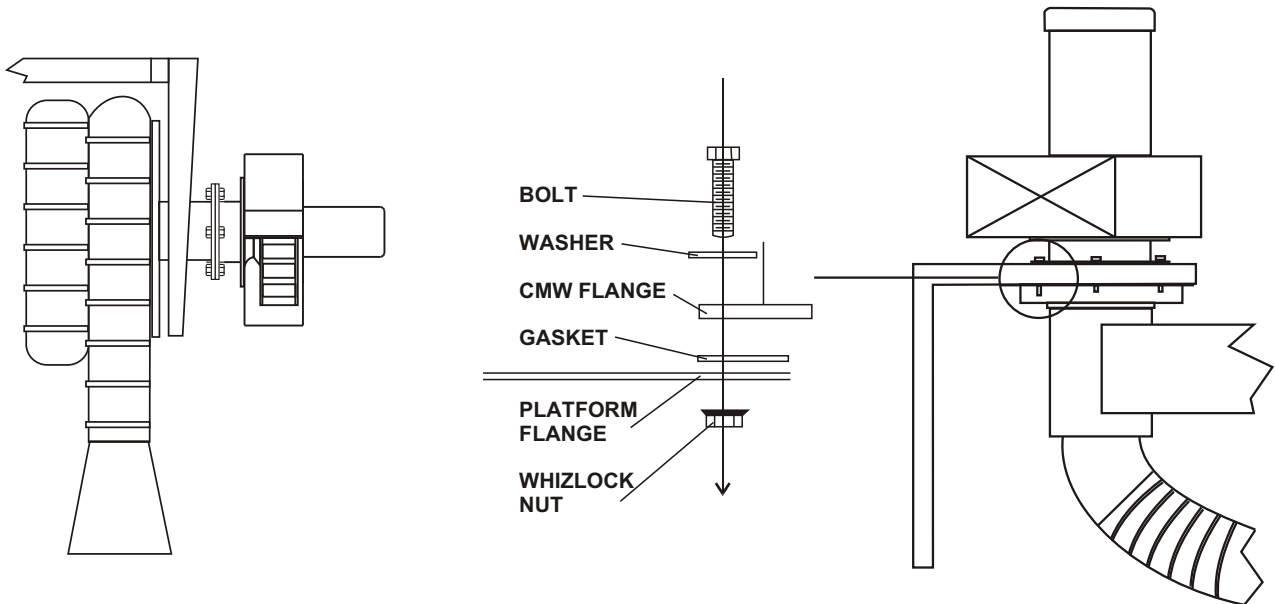

Tubing storage reels are usually shipped with CMW fans attached. If fans are not attached, bolt to reel flange, using gasket in between flanges.

Typical installation for mounting CMW fans on platforms used on welding arms, pipe booms, and other mounting platform applications.

INSTALLATION-OPERATION-MAINTENANCE

When fan is securely mounted and before it is wired, check fan wheel manually to make sure it turns freely without binding or striking the inlet or housing. If this condition exists, please contact the factory.

Wiring diagrams for most Baldor single and three phase motors are below. If your motor is not included on these diagrams, see motor faceplate or contact factory for diagram. The motor manufacturers offer some online or fax service for wiring diagrams. See page 4 of this guide for this information. After wiring, hit the "on" power button and then the "off" button. Check to see that the rotation of the fan is correct-if not recheck wiring. After checking rotation, turn fan on-keep a close watch for any unusual vibration or noise. If any vibration or noise occurs, stop and lock out the unit and recheck all parts and connections-if problem is not found, contact the factory.

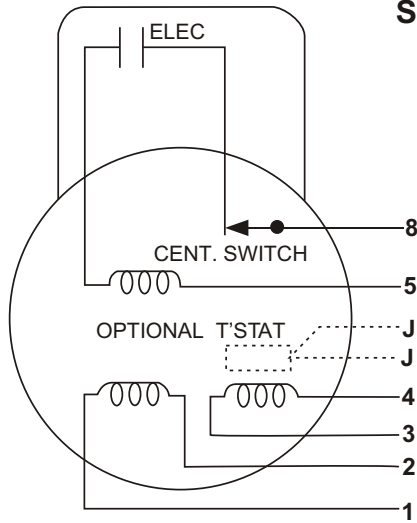

SINGLE PHASE, TYPE L, DUAL VOLTAGE REVERSIBLE, 6 LEAD

VOLT	↻	LINE A	LINE B	JOIN
HIGH	STD	1	4,5	2,3,8
HIGH	OPP	1	4,8	2,3,5
LOW	STD	1,3,8	2,4,5	-
LOW	OPP	1,3,5	2,4,8	-

This diagram covers most standard C-FACE, ODP, 1-phase Baldor motors (½ HP THRU 1½ HP) supplied on Car-Mon CMW flange mount fans. Check model numbers below.
 VL1303
 VL1306
 VL1309
 VL1313

WIRING DIAGRAM FOR THREE PHASE BALDOR MOTORS

This diagram covers most standard C-FACE, ODP, 3-phase Baldor motors (½ HP THRU 1½ HP) supplied on Car-Mon CMW flange mount fans. Check model numbers below.
 VM3107
 VM3111
 VM3115
 VM3120
 VM3155T

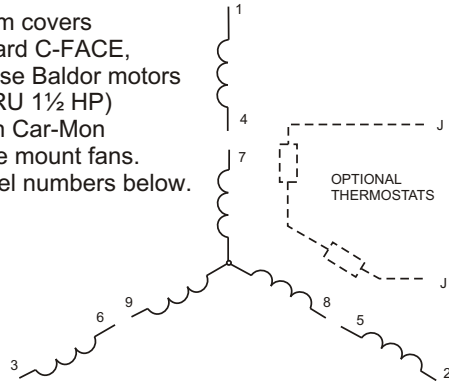
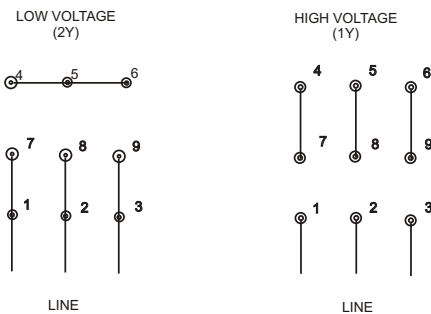

DIAGRAM SUPPLIED BY BALDOR ELECTRIC
3PH DV, 9 LEADS



NOTES:

1. INTERCHANGE ANY TWO LINE LEADS TO REVERSE ROTATION.
2. OPTIONAL THERMOSTATS ARE PROVIDED ONLY WHEN SPECIFIED.
3. ACTUAL NUMBER OF INTERNAL PARALLEL CIRCUITS MAY BE A MULTIPLE OF THOSE SHOWN ABOVE.

NOTE: IF THE MOTOR SHIPPED WITH THE FAN IS NOT LISTED ABOVE, A DIAGRAM CAN BE OBTAINED FROM THE MANUFACTURER. SEE PAGE 4 FOR INFORMATION.

INSTALLATION-OPERATION-MAINTENANCE

MAINTENANCE

A planned program of regularly scheduled maintenance will return dividends in averting a possible costly and unexpected period of down time. Following are some of the more important considerations.

1. Bolt and setscrew tightness.
2. Wheel wear or material build up on wheel causing unbalance will quickly damage bearings or cause self-destruction of the fan wheel.

SAFETY PRECAUTIONS

Any piece of machinery should be treated with respect. Following is a list of DO's and DON'Ts.

DO

1. If there is no outlet duct work, fan should be equipped with an outlet screen.
2. Make sure fan is stopped and electrical power locked out before putting hands into fan inlet or outlet opening. We suggest a warning sign on START switch cautioning not to start when fan is being serviced and a padlock on the disconnect.

DON'T

1. Put hands near or allow loose and hanging clothing to be near fan assembly.
2. Put hands into inlet or outlet while fan is running.

It is sometimes difficult to tell whether or not a fan is running. Be SURE it is not running and cannot be operated before any inspection.

LIMITED WARRANTY

Car-Mon Products, Inc. shall replace or repair at its discretion any products or components sold or manufactured which prove to be defective in workmanship or materials within 1 year from date of shipment.

The foregoing is in lieu of all warranties, expressed or implied, and all other obligations or liabilities on behalf of the company, regarding products it may manufacture or sell. Except as otherwise provided herein, the purchaser accepts the product "as is".

No warranty is made regarding the suitability or compatibility of any Car-Mon product for a particular application or purpose unless specifically stated. The Customer is responsible for the final selection and utilization of Car-Mon products for their use. The Customer assumes all liability for the consequences of performance, application, use and/or misuse by employees of products purchased from Car-Mon Products, Inc.

In no event shall Car-Mon Products, Inc. be liable for consequential or special damages; for transportation, labor, or other charges for adjustment, replacement, installation, incorrect electrical connections, overloading of motor, performance at low voltage, or other alterations which may be performed in connection with such products. The warranty specified herein is waived in the event that the Distributor, Contractor, or Purchaser perform any unauthorized repairs or modifications to the product.

With regard to products or components which are furnished by Car-Mon, Inc. but not manufactured by Car-Mon, Inc., the warranty obligation of Car-Mon shall be limited to and be the same as that of its supplier.

MOTOR WIRING GUIDES

If the motor on your fan does not match any of the wiring diagrams supplied, you may contact the factory or the motor manufacturer directly. All of the motor companies can be reached directly on the internet, with links to provide wiring diagrams. You may also contact them for the closest service center in the event you may need a warranty repair.

BALDOR MOTORS

www.baldor.com

Fax information to : 501-648-5791

MARATHON MOTORS

www.marathonelectric.com

LEESON MOTORS

www.leeson.com

Phone: 262.377.8810