

CAR-MON SERIES CMD DIRECT DRIVE EXHAUST FANS DIMENSIONS & SPECIFICATION

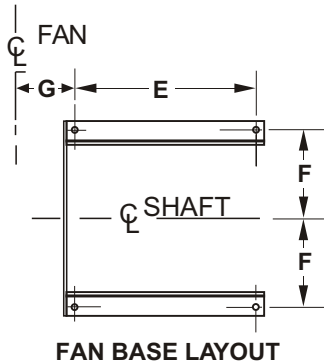

Note: Fan illustrated is clockwise,
bottom horizontal configuration

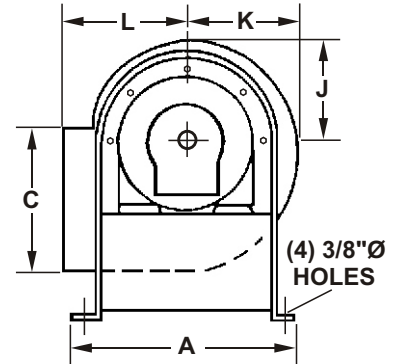
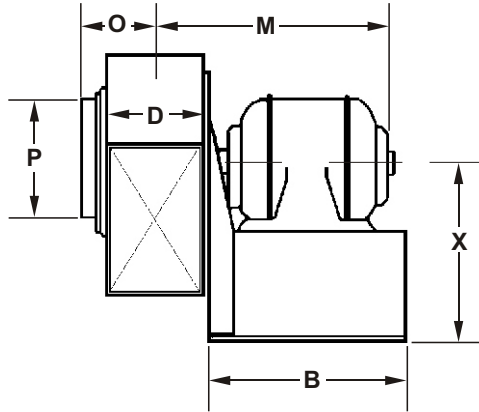

BLOWER DIMENSIONS IN INCHES

	A	B	C	D	E	F	G	J	K	L	M	O	P	X	WT.
CMD-5	9 ⁵ / ₈	8	7 ¹ / ₂	4 ¹ / ₄	6	4 ⁵ / ₁₆	3 ³ / ₁₆	4 ³ / ₄	5 ¹ / ₂	5 ¹ / ₂	10 ¹ / ₈	3 ¹ / ₈	6	8 ¹ / ₈	30
CMD-7	12 ⁵ / ₈	11	10	6 ¹ / ₂	9	5 ¹³ / ₁₆	4 ³ / ₈	7 ¹ / ₈	8 ¹ / ₂	7	13 ³ / ₈	4 ⁵ / ₈	8	10 ¹ / ₂	45
CMD-9	12 ⁵ / ₈	11	10	6 ¹ / ₂	9	5 ¹³ / ₁₆	4 ³ / ₈	7 ¹ / ₈	8 ¹ / ₂	7	13 ³ / ₈	4 ⁵ / ₈	8	10 ¹ / ₂	55
CMD-11	12 ⁵ / ₈	11	11 ¹ / ₂	8	9	5 ¹³ / ₁₆	5 ¹ / ₈	7 ⁵ / ₈	9	8	13 ³ / ₈	6 ¹ / ₈	8	12 ⁵ / ₈	60
CMD-13	15 ⁷ / ₈	11	12	6 ¹ / ₂	9	7 ⁷ / ₁₆	4 ³ / ₈	8	9 ³ / ₄	8 ¹ / ₂	13 ³ / ₈	4 ⁷ / ₁₆	9	12	100

SPECIFICATION: The fan shall be the standard product of a United States exhaust system manufacturer. Fan wheel shall be backward inclined, non-overloading type with single thickness blades and be statically and dynamically balanced. The mating surfaces of the inlet cone and fan housing shall be caulked prior to assembly. The inlet cone shall be assembled to the fan housing using hex head cap screws bolted to threaded inserts welded to the interior of the housing, self tapping screws are not acceptable. All surfaces of the fan and fan wheel shall be painted with an epoxy powder coating. The fan motor shall be an industrial grade foot mounted type, horsepower and electrical characteristics as specified. The fan shall be **Series CMD** as manufactured by Car-Mon Products, Elgin, IL 60123

CAR-MON Products, Incorporated

1225 Davis Road, Elgin, Illinois 60123
Phone (847) 695-9000 Fax (847) 695-9078
www.car-mon.com