

CAR-MON SERIES RCO REFUSE CLEAN-OUT PLENUM

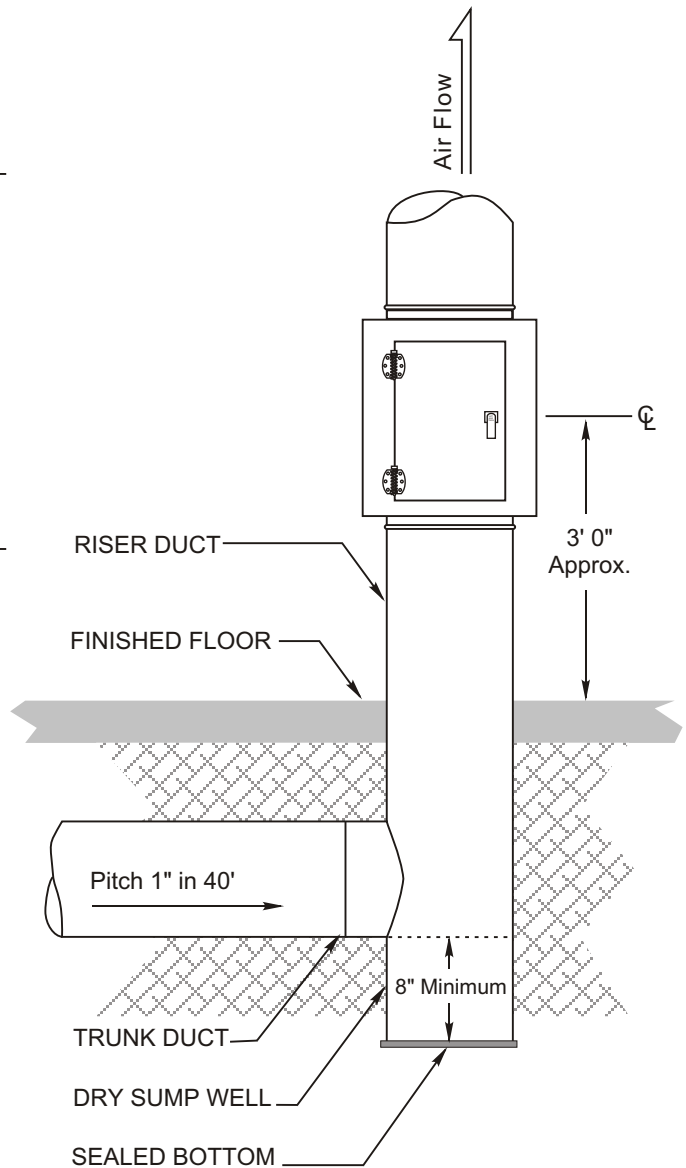
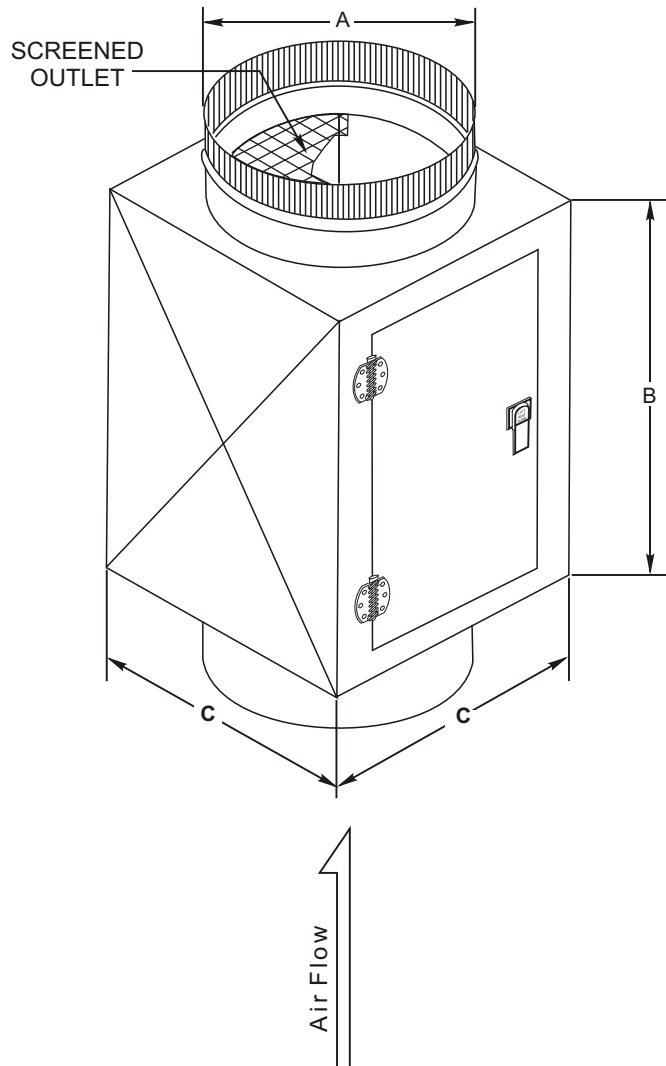

QTY.	MODEL	A	B	C	<p>Series RCO refuse clean-out plenums are designed as a debris trap to protect the exhaust fan while providing access to the underground ducting system through the riser duct for removal of accumulated refuse and insertion of a sump pump to eject water should the system become flooded.</p> <p>The refuse clean-out shall be constructed of minimum 20 gauge galvanized steel with positive close, gasketed access door with heavy duty, cad plated, spring loaded leaf spring, and adjustable draw latch. A screen mesh of ½" x ½" shall be provided across the outlet opening.</p> <p>Note: Factory reserves the right to change dimensional data without notice.</p>
	RCO-10	10"	16"	14"	
	RCO-12	12"	16"	16"	
	RCO-14	14"	16"	18"	
	RCO-16	16"	16"	20"	
	RCO-18	18"	16"	22"	