

SL INLINE FANS

Dimensions

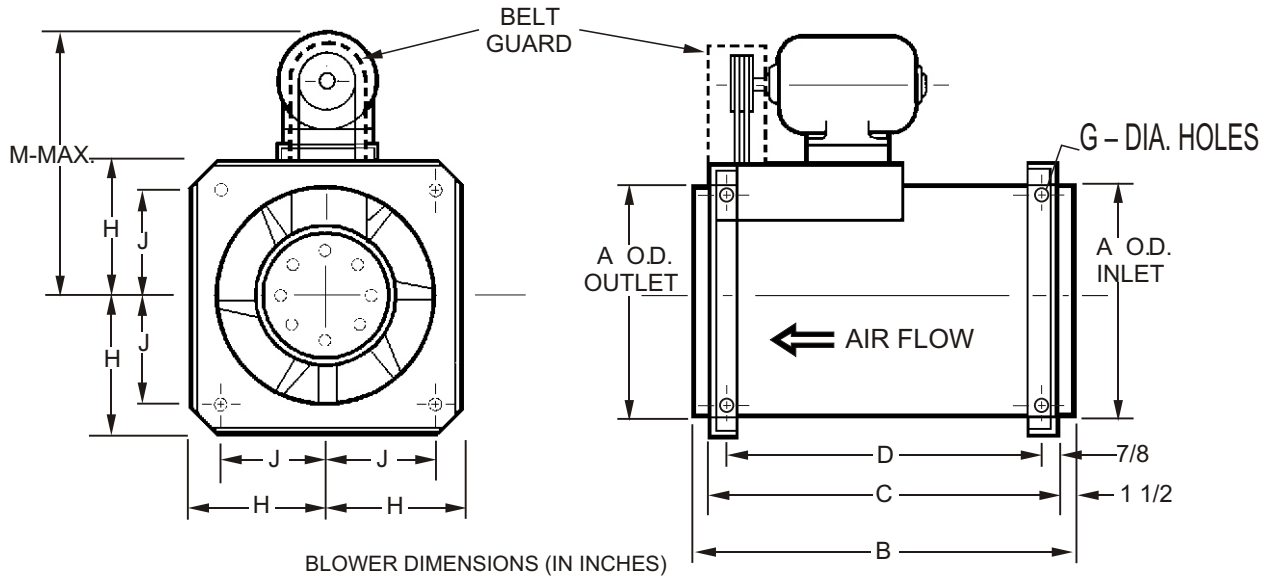

MODEL	A	B	C	D	G	H	J	M	WGT.
CM-8SL	14 ³ / ₄	24	21	19 ¹ / ₄	1/2	9 ¹ / ₄	6 ¹ / ₄	20	125
CM-10SL	14 ³ / ₄	24	21	19 ¹ / ₄	1/2	9 ¹ / ₄	6 ¹ / ₄	20	130
CM-14SL	17 ¹ / ₈	28	25	23 ¹ / ₄	1/2	10	7	27	155
CM-20SL	18 ³ / ₄	30 ¹ / ₄	27 ¹ / ₄	25 ¹ / ₂	1/2	11 ¹ / ₈	8	27 ⁷ / ₈	185
CM-25SL	20 ³ / ₄	33 ¹ / ₄	30 ¹ / ₄	28 ¹ / ₂	5/8	12 ¹ / ₄	9 ¹ / ₄	28 ⁷ / ₈	260
CM-30SL	25 ¹ / ₄	39 ¹ / ₄	36 ¹ / ₄	34 ¹ / ₂	5/8	15	12	33 ⁵ / ₈	325
CM-32SL	27 ³ / ₄	42 ³ / ₈	39 ³ / ₈	37 ⁵ / ₈	5/8	16 ¹ / ₂	13 ¹ / ₂	34 ⁷ / ₈	390
CM-35SL	30 ⁷ / ₈	48	45	43 ¹ / ₄	3/4	18 ¹ / ₄	15	36 ³ / ₈	490
CM-40SL	34	53 ³ / ₄	49 ³ / ₄	48	3/4	20 ¹ / ₄	17	45 ³ / ₄	625

CAR-MON
Products, Incorporated

1225 Davis Road, Elgin, Illinois 60123
 Phone (847) 695-9000 Fax (847) 695-9078
www.car-mon.com

Specification

SPECIFICATION: TUBULAR CENTRIFUGAL FAN

Fan shall be arrangement 9 in-line tubular centrifugal type with square endbells and backward inclined wheels with non-overloading horsepower characteristic. Fan shall be of the capacity, size and horsepower shown in the plans. Motor horsepowers, outlet velocities and speeds greater than those shown in the performance tables are not acceptable.

All wheels 12 inches in diameter and larger shall be of all welded construction with backwardly inclined blades. All wheels shall be statically and dynamically balanced. Housings shall be of tubular design using minimum 14 gauge steel and welded construction. The fan shall incorporate a minimum of 8 curved, die-formed conversion vanes at the discharge side of the wheel to provide maximum static pressure regain and minimum noise levels; in addition they provide internal structural support allowing the fan to be mounted vertically or horizontally from any side.

Shafts shall be designed so that fans operate at speeds well below first critical speed. Bearings shall be of heavy duty self-aligning lubricated type suitable for maximum thrust load in the vertical upblast position. Interior bearings requiring periodic lubrication shall be furnished with external lubrication fittings.

The V-belt drive shall be of the adjustable type and the variable pitch sheave shall be factory set at the approximate position to provide the specified capacity. All fans shall be provided with a belt guard enclosing the motor sheave and the V-belts. The belt guard shall have a tachometer hole. All drives for fans having 1 H.P. and larger motors shall have two V-belts.

The fans shall have all parts in the air stream painted with an air dry phenolic synthetic resinous coating. All exterior surfaces will be painted with an air dry machinery enamel.

The assembled fan shall be test run before shipment with "total frequency" vibration measured at each bearing in both the vertical and horizontal planes. Any fan having an average reading of over 3 mils deflection is not acceptable. **Balance report to be provided with installation and maintenance instructions.**

Series CM-SL exhaust fan shall be as manufactured by Car-Mon Products, Inc., Elgin, Illinois.

CAR-MON
Products, Incorporated

1225 Davis Road, Elgin, Illinois 60123
Phone (847) 695-9000 Fax (847) 695-9078
www.car-mon.com