

SERIES TS TUBING SLING

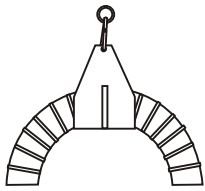

WITH HTX, CLX, & NE TUBING

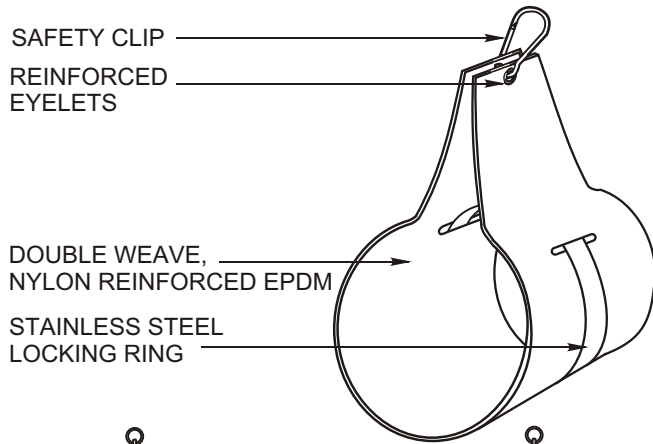
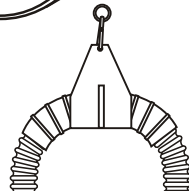

WITH NU-FLEX TUBING, NE SLEEVE IS USED

The Car-Mon **Series TS** Tubing Sling offers a safe and convenient way to raise and lower overhead assemblies. Used with the Car-Mon LFT 25/25, BA Balancer or PS and PSW pull-up sets, it can be placed anywhere along the length of hose to facilitate both operational placement and storage.

The tubing sling is constructed of a double weave, nylon reinforced EPDM material and has reinforced eyelets, a stainless steel locking band, safety clip and harness ring. The Series TS is available in sizes to fit hose from 3" to 8" in diameter. For larger sizes or for metal tubing, consult the factory.

Note: To avoid damage, never wrap cable or rope directly around non-metallic tubing.

QTY.	TUBE TYPE	TUBE DIAMETER	TUBE LENGTH	ADAPTER TYPE

SERIES SBF SAFETY BREAK-A-WAY FITTING

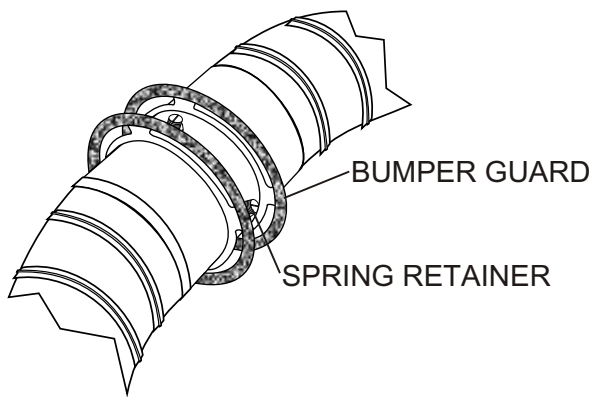

The backup safety break-a-way assembly is installed in a hose drop. It is comprised of two mating stainless steel sleeves with spring plunger retaining mechanism, factory adjusted and tested to allow for correct release pressure for separation if vehicle is inadvertently driven away without removing the connecting adapter from the vehicle exhaust. A protective ring with rubberized bumper strip is incorporated into the sleeve assemblies to minimize potential damage to vehicle and/or building.

Quantity	Model	Size
	SBF-4	4"
	SBF-5	5"
	SBF-6	6"
	SBF-8	8"

SERIES PP ADAPTER POSITIONING POLE

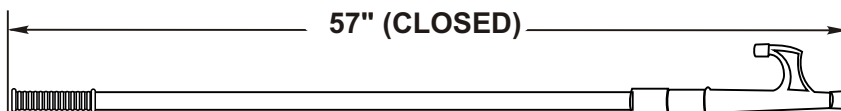

QTY.	
------	--

Series PP Adapter Positioning Pole does not require additional fittings on the adapter for its use. It can be used to place almost any exhaust adapter from the ground. The pole is adjustable to 104" and is 57" in the closed position.